

Gypsum Board Partitions - Steel Framing

1 Hour FIRE	Design #	GA File #	STC - 38	
	OSU T-3296	WP 1340	Sound Test #	NGC - 2384

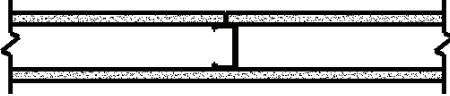

[Link to .PDF file](#)
[Link to .DWG file](#)
[Link to .DWG/Text file](#)

5/8" (15.9 mm) Fire-Shield Gypsum Board or 5/8" XP Fire-Shield Gypsum Board applied vertically to each side of 1-5/8" steel studs 24" o.c. with 1" type S drywall screws 8" o.c. at edges and floor and ceiling runners and 12" o.c. at intermediate studs. Joints staggered 24" on opposite side.

1 Hour FIRE	Design #	GA File #	STC - 52	
	UL U420	WP 5015	Sound Test #	TL-76-155

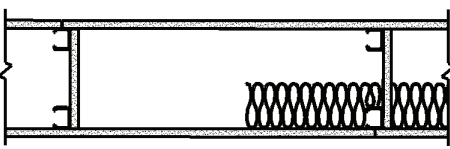

[Link to .PDF file](#)
[Link to .DWG file](#)
[Link to .DWG/Text file](#)

Chase wall, 5/8" (15.9 mm) Fire-Shield Gypsum Board applied vertically to a double row of 1-5/8" steel studs 24" o.c. and 6-1/4" apart with 1" type S screws 8" o.c. at edges and floor and ceiling runners and 12" o.c. at intermediate studs. 5/8" gypsum board pieces 12" wide x 9-1/2" long located at 1/3 points used as cross braces fastened to stud pairs with three 1" type S drywall screws at each end of brace. Option for 25 gauge 9-1/2" long stud or runner pieces may be used as cross braces and attached with two No. 8 x 1/2" or 5/8" self drilling steel screws at each end. Joints staggered 24" on opposite sides. Sound test with 3-1/2" mineral wool or glass fiber insulation in stud cavity.

1 Hour FIRE	Design #	GA File #	STC - 40	
	OSU T-3296	WP 1340	Sound Test #	NGC - 2438



[Link to .PDF file](#)
[Link to .DWG file](#)
[Link to .DWG/Text file](#)

5/8" (15.9 mm) Fire-Shield Gypsum Board or 5/8" XP Fire-Shield Gypsum Board applied vertically to each side of 1-5/8" steel studs 24" o.c. with 1" type S drywall screws 8" o.c. at edges and floor and ceiling runners and 12" o.c. at intermediate studs. Option for 2-1/2" mineral wool or glass fiber insulation in stud cavity. Joints staggered 24" on opposite side.

Sound test with 2-1/2" batt insulation = STC 45 (NGC-2391)

1 Hour FIRE	Design #	GA File #	STC - 45	
	UL V401/UL V438	WP 1070	Sound Test #	NGC-2179



[Link to .PDF file](#)
[Link to .DWG file](#)
[Link to .DWG/Text file](#)

1/2" (12.7 mm) Fire-Shield C Gypsum Board applied vertically to each side of 2-1/2" steel studs 24" o.c. with 1" type S drywall screws 8" o.c. at vertical joints and 12" o.c. at intermediate studs. 2" mineral fiber insulation, 2.5 pcf, friction fit in stud cavity. Joints staggered 24" on opposite sides.

Gypsum Board Partitions - Steel Framing (Continued)

1 Hour FIRE	Design #	GA File #	STC - 45	
	UL V401/UL V438	WP 1071	Sound Test #	NGC - 2179



[Link to .PDF file](#)
[Link to .DWG file](#)
[Link to .DWG/Text file](#)

1/2" (12.7 mm) Fire-Shield C Gypsum Board applied horizontally to each side of 2-1/2" steel studs 24" o.c. with 1" type S drywall screws 8" o.c. at vertical joints and 12" o.c. at intermediate studs. 2" mineral fiber insulation, 3.0 pcf, friction fit in stud cavity. Vertical joints staggered 24" on each side and opposite sides. Horizontal joints need not be staggered.

1 Hour FIRE	Design #	GA File #	STC - 47	
	UL V401 or UL V438	WP 1081	Sound Test #	NGC - 2386

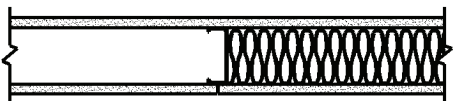

[Link to .PDF file](#)
[Link to .DWG file](#)
[Link to .DWG/Text file](#)

5/8" (15.9 mm) Fire-Shield Gypsum Board applied vertically to each side of 3-5/8" steel studs 24" o.c. with 1" type S drywall screws 8" o.c. at vertical joints and 12" o.c. at floor and ceiling runners and intermediate studs. Joints staggered 24" on opposite side. Option for 2-1/2" mineral wool or glass fiber insulation in stud cavity. Option for horizontal resilient channel 24" o.c. applied to studs with one 1/2" type S-12 pan head screw at each stud intersection.

1 Hour FIRE	Design #	GA File #	STC - 47	
	UL U465 or UL V438	WP 1081	Sound Test #	NGC - 2386



[Link to .PDF file](#)
[Link to .DWG file](#)
[Link to .DWG/Text file](#)

5/8" (15.9 mm) Fire-Shield Gypsum Board applied vertically to each side of 3-5/8" steel studs 24" o.c. with 1" type S drywall screws 8" o.c. at vertical joints and 12" o.c. at floor and ceiling runners and intermediate studs. Joints staggered 24" on opposite side.

1 Hour FIRE	Design #	GA File # BASED ON	STC - 47	
	UL V438 or UL U465	WP 1072	Sound Test #	NGC - 2386

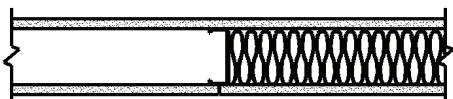

[Link to .PDF file](#)
[Link to .DWG file](#)
[Link to .DWG/Text file](#)

5/8" (15.9 mm) Fire-Shield Gypsum Board applied horizontally to each side of 3-5/8" steel studs 24" o.c. with 1" type S drywall screws 1-1/2" and 3" from board edges and 8" o.c. in the field. Screws spaced a maximum of 12" along top and bottom edge of wall. Horizontal joints need not be backed by steel framing. Horizontal joints need not be staggered on each side.

Gypsum Board Partitions - Steel Framing (Continued)

1 Hour FIRE	Design #	FM WP-45	GA File #	STC - 47	
			WP 1072	Sound Test #	NGC - 2386



[Link to .PDF file](#)
[Link to .DWG file](#)
[Link to .DWG/Text file](#)

5/8" (15.9 mm) Fire-Shield Gypsum Board applied horizontally to each side of 3-5/8" steel studs 24" o.c. with 1" type S drywall screws 8" o.c. at vertical joints and 12" o.c. at floor and ceiling runners and intermediate studs. Joints staggered 24" on opposite side. Option for 2-1/2" mineral wool or glass fiber insulation in stud cavity.

1 Hour FIRE	Design #	UL V452	GA File #	STC - 45	
			WP 1082	Sound Test #	NGC-2099015



[Link to .PDF file](#)
[Link to .DWG file](#)
[Link to .DWG/Text file](#)

1/2" (12.7 mm) PermaBase Cement Board applied horizontally or vertically to one side of 3-5/8" steel studs 16" o.c. with 1-1/4" cement board screws 8" o.c. 5/8" (15.9 mm) Fire-Shield Gypsum Board applied vertically to opposite side with 1-1/4" type S drywall screws 8" o.c. on perimeter and 12" o.c. in the field. Joints staggered 24" on opposite side. 3" mineral wool insulation batts required in stud cavity.

1 Hour FIRE	Design #	FM WP-66	GA File #	STC - 43	
			WP 1021	Sound Test #	NGC - 2248

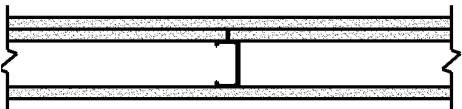

[Link to .PDF file](#)
[Link to .DWG file](#)
[Link to .DWG/Text file](#)

1/2" (12.7 mm) Fire-Shield C Gypsum Board applied vertically to one side of 2-1/2" steel studs 24" o.c. with 1" type S drywall screws 8" o.c. at vertical joints and 3/8" adhesive beads at intermediate studs. Opposite Side: Base layer 1/2" Fire-Shield C Gypsum Board applied vertically with 1" type S drywall screws 8" o.c. at vertical joints and 12" o.c. at intermediate studs. Face layer 1/2" Fire-Shield C Gypsum Board applied vertically with 1-5/8" type S drywall screws 8" o.c. at vertical joints and 5/8" adhesive beads at intermediate studs. Vertical joints staggered 24" on each layer and side.

Sound test with 3" fiber glass insulation = STC 50 ([NGC-2253](#))

1 Hour FIRE	Design #	FM WP-733	GA File #	STC - 43	
			WP 1022	Sound Test #	NGC - 2248

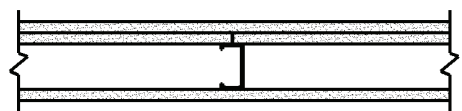

[Link to .PDF file](#)
[Link to .DWG file](#)
[Link to .DWG/Text file](#)

1/2" (12.7 mm) Fire-Shield C Gypsum Board applied horizontally to one side of 2-1/2" steel studs 24" o.c. with 1" type S drywall screws 8" o.c. at vertical joints and 12" o.c. at intermediate studs and perimeter. Opposite Side: Base layer 1/2" Fire-Shield C Gypsum Board applied horizontally with 1" type S drywall screws 12" o.c. Face layer 1/2" Fire-Shield C Gypsum Board applied horizontally with 1-5/16" type S drywall screws 8" o.c. at vertical joints and 12" at intermediate studs and wall perimeter. Joints staggered 24" on each layer and side.

Gypsum Board Partitions - Steel Framing (Continued)

1 Hour FIRE	Design #	BASED ON	GA File #	BASED ON	STC - 44
	FM WP-66	WP 1021			Sound Test #

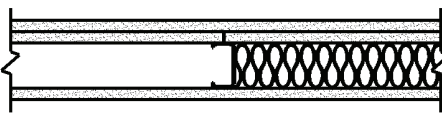

[Link to .PDF file](#)
[Link to .DWG file](#)
[Link to .DWG/Text file](#)

1/2" (12.7 mm) Fire-Shield C Gypsum Board applied vertically to one side of 3-5/8" steel studs 24" o.c. with 1" type S drywall screws 8" o.c. at vertical joints and 12" o.c. at intermediate studs and perimeter. Opposite Side: Base layer 1/2" Fire-Shield C Gypsum Board applied horizontally with 1" type S drywall screws 12" o.c. Face layer 1/2" Fire-Shield C Gypsum Board applied horizontally with 1-5/16" type S drywall screws 8" o.c. at vertical joints and 12" at intermediate studs and wall perimeter. Joints staggered 24" on each layer and side.

Sound test with 3" fiber glass insulation = STC 50 ([NGC-2253](#))

1 Hour FIRE	Design #	BASED ON	GA File #	BASED ON	STC - 44
	FM WP-45	WP 1052			Sound Test #

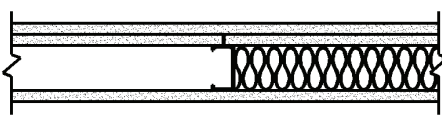

[Link to .PDF file](#)
[Link to .DWG file](#)
[Link to .DWG/Text file](#)

5/8" (15.9 mm) Fire-Shield Gypsum Board or 5/8" XP Fire-Shield Gypsum Board applied vertically to one side of 3-5/8" steel studs 24" o.c. with 1" type S drywall screws 8" o.c. at vertical joints and 12" o.c. at intermediate studs and perimeter. Opposite Side: Base layer 5/8" Fire-Shield Gypsum Board or 5/8" XP Fire-Shield Gypsum Board applied vertically with 1" type S drywall screws 8" o.c. at vertical joints and 12" o.c. at intermediate studs and perimeter. Face layer 5/8" Fire-Shield Gypsum Board or 5/8" XP Fire-Shield Gypsum Board applied vertically with 1-5/8" type S drywall screws 12" o.c. Joints staggered 24" on each layer and side.

Sound test with 3" fiber glass insulation = STC 50 (NRCC 817-NV)

1.5 Hour FIRE	Design #	BASED ON	GA File #	BASED ON	STC - 44
	OSU T-3240			Sound Test #	NGC-2388

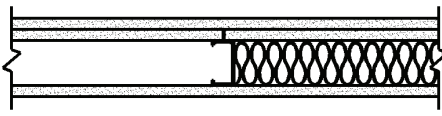

[Link to .PDF file](#)
[Link to .DWG file](#)
[Link to .DWG/Text file](#)

5/8" (15.9 mm) Fire-Shield Gypsum Board or 5/8" XP Fire-Shield Gypsum Board applied vertically to one side of 3-5/8" steel studs 24" o.c. with 1" type S drywall screws 8" o.c. at vertical joints and 12" o.c. at intermediate studs and perimeter. Opposite Side: Base layer 5/8" Fire-Shield Gypsum Board or 5/8" XP Fire-Shield Gypsum Board applied vertically with 1" type S drywall screws 8" o.c. at vertical joints and 12" o.c. at intermediate studs and perimeter. Face layer 5/8" Fire-Shield Gypsum Board or 5/8" XP Fire-Shield Gypsum Board applied vertically with 1-5/8" type S drywall screws 12" o.c. Joints staggered 24" on each layer and side.

1 Hour FIRE	Design #	BASED ON	GA File #	BASED ON	STC - 50
	UL U451	WP 1071			Sound Test #

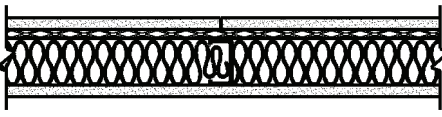

[Link to .PDF file](#)
[Link to .DWG file](#)
[Link to .DWG/Text file](#)

1/2" (12.7 mm) Fire-Shield C Gypsum Board applied vertically to one side of 2-1/2" steel studs 24" o.c. with 1" type S drywall screws 12" o.c. Opposite Side: resilient furring channels spaced 24" o.c. attached to studs with 1" type S drywall screws. Layer 1/2" Fire-Shield C Gypsum Board applied vertically to resilient furring channel with 1" type S drywall screws 12" o.c. Joints staggered 24" on each side. 3" thick (3pcf) mineral wool insulation friction fit into stud cavity.

Gypsum Board Partitions - Steel Framing (Continued)

1 Hour FIRE	Design #	UL U410	GA File #	STC - 45		
			WP 1051	Sound Test #	NGC - 2328	
			<p>Base layer 1/4" gypsum board applied vertically to each side of 2-1/2" steel studs 24" o.c. with 1" type S drywall screws 12" o.c. Face layer 1/2" (12.7 mm) Fire-Shield C Gypsum Board applied vertically to each side with 1/4" beads of laminating compound 2" o.c. to full field of Face layer and 1-5/8" type S drywall screws 8" o.c. at floor and ceiling runners only. Joints staggered 24" on each side.</p> <p>*Sound test with 2" fiberglass insulation =STC 53 (NGC-2318)</p>			
		<p style="text-align: center;"> Link to .PDF file Link to .DWG file Link to .DWG/Text file </p>				

2 Hour FIRE	Design #	UL V449	GA File #	STC - N/A		
			WP 1943	Sound Test #	N/A	
			<p>Base layer 5/8" (15.9 mm) Fire-Shield Gypsum Board applied vertically to each side of 3-1/2" steel studs 24" o.c. with 1-1/8" type S drywall screws 8" o.c. at vertical joints and wall perimeter and 12" o.c. at intermediate studs.</p> <p>Second layer 5/8" Fire-Shield Gypsum Board applied vertically to one side with 1-5/8" type S drywall screws 12" o.c. Face layer 5/8" Fire-Shield Gypsum Board applied vertically to one side with 2-1/4" type S drywall screws 8" o.c. at vertical joints and wall perimeter and 12" o.c. at intermediate studs. Joints staggered 24" on each layer and side.</p>			
		<p style="text-align: center;"> Link to .PDF file Link to .DWG file Link to .DWG/Text file </p>				

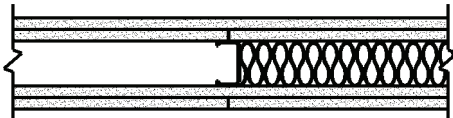
2 Hour FIRE	Design #	UL V438	GA File #	STC - N/A		
			WP 1530	Sound Test #	N/A	
			<p>Base layer 1/2" (12.7 mm) Fire-Shield C Gypsum Board applied vertically to each side of 1-5/8" steel studs 24" o.c. with 1" type S drywall screws 16" o.c. Face layer 1/2" Fire-Shield C Gypsum Board applied vertically or horizontally with 1-5/8" type S drywall screws 16" o.c. Screws offset 8" from base layer. Joints staggered 24" on each layer and side.</p>			
		<p style="text-align: center;"> Link to .PDF file Link to .DWG file Link to .DWG/Text file </p>				

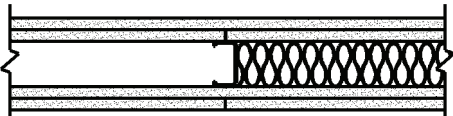
2 Hour FIRE	Design #	UL U412	GA File #	STC - 46		
			WP 1615	Sound Test #	NGC-2250	
			<p>Base layer 1/2" (12.7 mm) Fire-Shield C Gypsum Board applied vertically to each side of 2-1/2" steel studs 24" o.c. with 1" type S drywall screws 24" o.c. Face layer 1/2" Fire-Shield C Gypsum Board applied vertically or horizontally with 1-5/8" type S drywall screws 12" o.c. Joints staggered 24" on each layer and side.</p> <p>*Sound test with 3" fiberglass insulation =STC 53 (NGC-2252)</p>			
		<p style="text-align: center;"> Link to .PDF file Link to .DWG file Link to .DWG/Text file </p>				

Gypsum Board Partitions - Steel Framing (Continued)

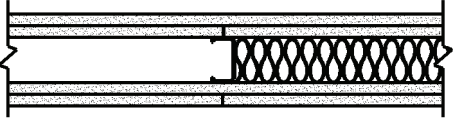
2 Hour FIRE	Design #	GA File #	STC - 56	
	UL U411	WP 1548	Sound Test #	NGC - 3022
		<p>Base layer 5/8" (15.9 mm) Fire-Shield Gypsum Board applied vertically to each side of 2-1/2" steel studs 24" o.c. with 1" type S drywall screws 16" o.c. Face layer 5/8" Fire-Shield Gypsum Board applied vertically with 1-5/8" type S drywall screws 16" o.c. at vertical joints and intermediate studs and 12" o.c. at floor and ceiling runners. Joints staggered 24" on each layer and side.</p> <p>*Sound test with 3" fiberglass insulation</p>		
<p>Link to .PDF file Link to .DWG file Link to .DWG/Text file</p>				

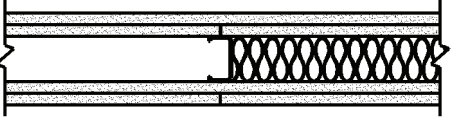
2 Hour FIRE	Design #	GA File #	BASED ON	STC - N/A	
	UL V438	WP 1548		Sound Test #	N/A
		<p>Base layer 5/8" (15.9 mm) Fire-Shield Gypsum Board applied vertically to each side of 2-1/2" steel studs 24" o.c. with 1" type S drywall screws 16" o.c. Face layer 5/8" Fire-Shield Gypsum Board applied vertically or horizontally with 1-5/8" type S drywall screws 16" o.c. Screws offset 8" from base layer. Joints staggered 24" on each layer and side.</p>			
<p>Link to .PDF file Link to .DWG file Link to .DWG/Text file</p>					

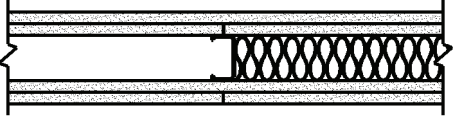
2 Hour FIRE	Design #	GA File #	BASED ON	STC - N/A	
	UL V438	WP 1548		Sound Test #	N/A
		<p>Base layer 5/8" (15.9 mm) Fire-Shield Gypsum Board applied horizontally to each side of 2-1/2" steel studs 24" o.c. with 1" type S drywall screws 24" o.c., with first screw installed 1-1/4" from board edge and to track only spaced 24" o.c. Face layer 5/8" Fire-Shield Gypsum Board applied horizontally with 1-5/8" type S drywall screws 16" o.c. with first and second screws installed 1-1/4" and 8" from the board edge respectively, and to the track only spaced 16" o.c. Vertical joints staggered one stud cavity on each side. Horizontal edge joints need not be staggered on opposite side of stud. Horizontal edge joints must be staggered minimum of 12" from adjacent layers.</p>			
<p>Link to .PDF file Link to .DWG file Link to .DWG/Text file</p>					

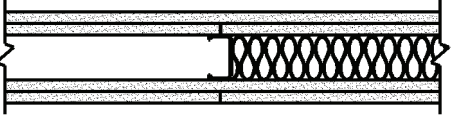
2 Hour FIRE	Design #	GA File #	BASED ON	STC - 48	
	UL U412	WP 1615		Sound Test #	NGC-2282
		<p>Base layer 1/2" (12.7 mm) Fire-Shield C Gypsum Board applied vertically to each side of 3-5/8" steel studs 24" o.c. with 1" type S drywall screws 24" o.c. Face layer 1/2" Fire-Shield C Gypsum Board applied vertically or horizontally with 1-5/8" type S drywall screws 12" o.c. Joints staggered 24" on each layer and side.</p> <p>*Sound test with 3" fiberglass insulation =STC 53 (NGC-2288)</p>			
<p>Link to .PDF file Link to .DWG file Link to .DWG/Text file</p>					

Gypsum Board Partitions - Steel Framing (Continued)

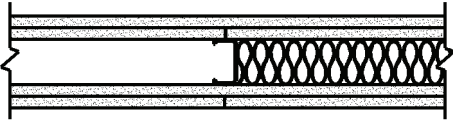
2 Hour FIRE	Design #	GA File #	STC - 56	
	UL U411	WP 1548	Sound Test #	NGC-3022
		<p>Base layer 5/8" (15.9 mm) Fire-Shield Gypsum Board applied vertically to each side of 3-5/8" steel studs 24" o.c. with 1" type S drywall screws 16" o.c. Face layer 5/8" Fire-Shield Gypsum Board applied vertically with 1-5/8" type S drywall screws 16" o.c. at vertical joints and intermediate studs and 12" o.c. at floor and ceiling runners. Joints staggered 24" on each layer and side.</p> <p style="text-align: right;">*Sound test with 3" fiberglass insulation</p>		
<p>Link to .PDF file Link to .DWG file Link to .DWG/Text file</p>				

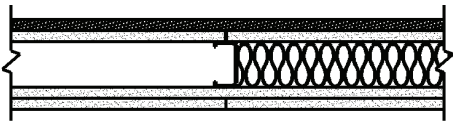
2 Hour FIRE	Design #	GA File #	STC - 52	
	UL V452	WP 1565	Sound Test #	NGC - 2099016
		<p>Face layer 1/2" (12.7 mm) PermaBase cement board applied vertically to one side of 3-5/8" steel studs 16" o.c. with 1-5/8" cement board screws 8" o.c. Base layer 1/2" (12.7 mm) Fire-Shield C Gypsum Wallboard applied vertically with 1" type S drywall screws 24" o.c. Opposite side: Base layer 1/2" Fire-Shield C Gypsum Wallboard applied vertically with 1" type S drywall screws 24" o.c. Face layer 1/2" Fire-Shield C Gypsum Wallboard applied vertically with 1-5/8" type S drywall screws 12" o.c. 3" mineral wool insulation batts required in stud cavity. Joints staggered on each layer and side.</p>		
<p>Link to .PDF file Link to .DWG file Link to .DWG/Text file</p>				

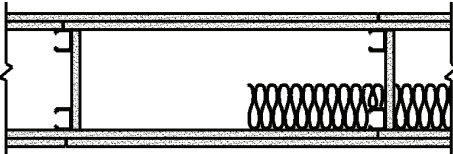
2 Hour FIRE	Design #	GA File #	STC - 57	
	UL U420	WP 5105	Sound Test #	TL-76-156
		<p>Base layer 5/8" (15.9 mm) Fire-Shield Gypsum Board applied vertically to a double row of 1-5/8" steel studs 24" o.c. and 6-1/4" apart with 1" type S screws 8" o.c. at edges and floor and ceiling runners and 12" o.c. at intermediate studs. Face layer 5/8" Fire-Shield Gypsum Board applied vertically with 1-5/8" type S screws 8" o.c. at edges and floor and ceiling runners and 12" o.c. at intermediate studs. gypsum board pieces 12" wide x 9-1/2" long located at 1/3 points used as cross braces fastened to stud pairs with three 1" type S drywall screws at each end of brace. Option for 25 gauge 9-1/2" long stud or runner pieces may be used as cross braces and attached with two No. 8 x 1/2" or 5/8" self drilling steel screws at each end. Joints staggered 24" on each layer and side. Sound test with 3-1/2" mineral wool or glass fiber insulation in stud cavity.</p>		
<p>Link to .PDF file Link to .DWG file Link to .DWG/Text file</p>				

Gypsum Board Partitions - Steel Framing (Continued)

3 Hour FIRE	Design #	GA File #	STC - 48	
	UL U435	WP 2921	Sound Test #	NGC-2631

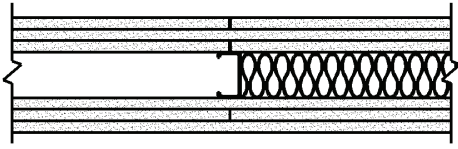

[Link to .PDF file](#)
[Link to .DWG file](#)
[Link to .DWG/Text file](#)

Base layer 1/2" (12.7 mm) Fire-Shield C Gypsum Board applied vertically to each side of 1-5/8" steel studs 24" o.c. with 1" type S drywall screws 12" o.c. Second layer 1/2" Fire-Shield C Gypsum Board applied vertically to each side with 1-5/8" type S drywall screws 30" o.c. and 1-1/2" type G drywall screws 12" o.c. spaced 1-1/2" from vertical joints. Vertical joints located 8" from studs and staggered 24" on opposite sides. Face layer 1/2" Fire-Shield Gypsum Board applied horizontally to each side with 2-1/4" type S drywall screws 12" o.c. and 1-1/2" type G drywall screws midway between studs 1-1/2" above and below horizontal joints. Joints offset 24" from second layer joints.

*Sound test with 1-1/2" fiberglass or mineral wool insulation =STC 53 ([NGC-2636](#))

3 Hour FIRE	Design #	GA File #	BASED ON	STC - 48	
	UL V438	WP 2921		Sound Test #	NGC-2631

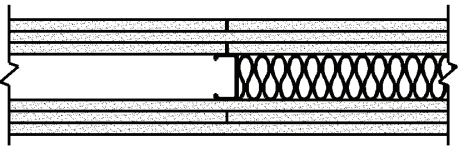

[Link to .PDF file](#)
[Link to .DWG file](#)
[Link to .DWG/Text file](#)

Base layer 1/2" (12.7 mm) Fire-Shield C Gypsum Board applied vertically to each side of 1-5/8" steel studs 24" o.c. with 1" type S drywall screws 24" o.c. Second layer 1/2" Fire-Shield C Gypsum Board applied vertically to each side with 1-5/8" type S drywall screws 24" o.c. Face layer 1/2" Fire-Shield C Gypsum Board applied vertically or horizontally to each side with 2-1/4" type S drywall screws 12" o.c. Screws offset 6" from layer below. Joints staggered one stud cavity each layer and side.

*Sound test with 1-1/2" fiberglass or mineral wool insulation =STC 53 ([NGC-2636](#))

3 Hour FIRE	Design #	GA File #	STC - 48		
	UL V438	N/A	Sound Test #	Based on NGC-2631	

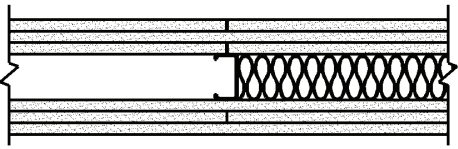

[Link to .PDF file](#)
[Link to .DWG file](#)
[Link to .DWG/Text file](#)

Base layer 5/8" (15.9 mm) Fire-Shield Gypsum Board applied vertically to each side of 1-5/8" steel studs 24" o.c. with 1" type S drywall screws 24" o.c. Second layer 5/8" Fire-Shield Gypsum Board applied vertically to each side with 1-5/8" type S drywall screws 24" o.c. Face layer 5/8" Fire-Shield Gypsum Board applied vertically or horizontally to each side with 2-5/8" type S drywall screws 12" o.c. Screws offset 6" from layer below. Joints staggered one stud cavity each layer and side.

*Sound test with 1-1/2" fiberglass or mineral wool insulation =STC 53 ([Based on NGC-2636](#))

Gypsum Board Partitions - Steel Framing (Continued)

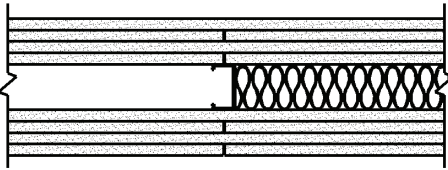
4 Hour FIRE	Design #	GA File #	STC - 51	
	UL U435	WP 2970	Sound Test #	NGC-2633
 <p style="text-align: center; margin-top: 10px;"> Link to .PDF file Link to .DWG file Link to .DWG/Text file </p>	<p>Base layer 1/2" (12.7 mm) Fire-Shield C Gypsum Board applied vertically to each side of 1-5/8" steel studs 24" o.c. with 1" type S drywall screws 48" o.c. on studs and 24" o.c. at floor and ceiling runners. Joints staggered 24" on opposite sides. Second layer 1/2" Fire-Shield C Gypsum Board applied vertically to each side with 1-5/8" type S drywall screws 12" o.c.</p> <p>Joints aligned with base layer joints. Third layer 1/2" Fire-Shield C Gypsum Board applied vertically to each side with 2-1/4" type S drywall screws 30" o.c. and 1-1/2" type G drywall screws 12" o.c. spaced 1-1/2" from vertical joints. Vertical joints located 8" from studs and staggered 24" on opposite sides. Face layer 1/2" Fire-Shield Gypsum Board applied horizontally to each side with 2-5/8" type S drywall screws 12" o.c. and 1-1/2" type G drywall screws midway between studs 1-1/2" above and below horizontal joints. Joints offset 24" from third layer joints.</p> <p style="margin-top: 20px;">*Sound test with 1-1/2" fiberglass or mineral wool insulation =STC 55 (NGC-2634)</p>			

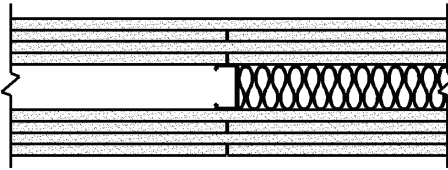
4 Hour FIRE	Design #	GA File #	STC - 51	
	UL V438	BASED ON WP 2970	Sound Test #	Based on NGC-2633
 <p style="text-align: center; margin-top: 10px;"> Link to .PDF file Link to .DWG file Link to .DWG/Text file </p>	<p>Base layer 1/2" (12.7 mm) Fire-Shield C Gypsum Board applied vertically to each side of 1-5/8" steel studs 24" o.c. with 1" type S drywall screws 24" o.c. Second layer 1/2" Fire-Shield C Gypsum Board applied vertically to each side with 1-5/8" type S drywall screws 24" o.c. Third layer 1/2" Fire-Shield C Gypsum Board applied vertically to each side with 2-1/4" type S drywall screws 24" o.c. Face layer 1/2" Fire-Shield C Gypsum Board applied vertically or horizontally to each side with 2-5/8" type S drywall screws 12" o.c. Screws offset 6" from layer below. Joints staggered one stud cavity each layer and side.</p> <p style="margin-top: 20px;">*Sound test with 1-1/2" fiberglass or mineral wool insulation =STC 55 (Based on NGC-2634)</p>			

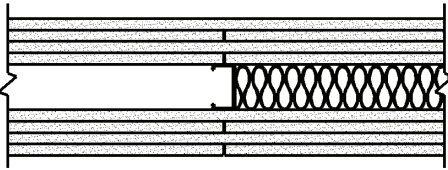
4 Hour FIRE	Design #	GA File #	STC - 51	
	UL V438	BASED ON WP 2970	Sound Test #	Based on NGC-2633
 <p style="text-align: center; margin-top: 10px;"> Link to .PDF file Link to .DWG file Link to .DWG/Text file </p>	<p>Base layer 5/8" (15.9 mm) Fire-Shield Gypsum Board applied vertically to each side of 1-5/8" steel studs 24" o.c. with 1" type S drywall screws 24" o.c. Second layer 5/8" Fire-Shield Gypsum Board applied vertically to each side with 1-5/8" type S drywall screws 24" o.c. Third layer 5/8" Fire-Shield Gypsum Board applied vertically to each side with 2-5/8" type S drywall screws 24" o.c. Face layer 5/8" Fire-Shield Gypsum Board applied vertically or horizontally to each side with 3" type S drywall screws 12" o.c. Screws offset 6" from layer below. Joints staggered one stud cavity each layer and side.</p> <p style="margin-top: 20px;">*Sound test with 1-1/2" fiberglass or mineral wool insulation =STC 55 (Based on NGC-2634)</p>			