



ICC Evaluation Service, Inc.
www.icc-es.org

Business/Regional Office ■ 5360 Workman Mill Road, Whittier, California 90601 ■ (562) 699-0543
Regional Office ■ 900 Montclair Road, Suite A, Birmingham, Alabama 35213 ■ (205) 599-9800
Regional Office ■ 4051 West Flossmoor Road, Country Club Hills, Illinois 60478 ■ (708) 799-2305

Legacy report on the 1997 Uniform Building Code™

DIVISION: 09—FINISHES

Section: 09260—Gypsum Board Assemblies

ONE- AND TWO-HOUR FIRE-RESISTIVE GOLD BOND INTERIOR PARTITION SYSTEMS

NATIONAL GYPSUM COMPANY

1650 MILITARY ROAD
BUFFALO, NEW YORK 14217-1198

PHILLIPS MANUFACTURING COMPANY

4601 SOUTH 76TH
OMAHA, NEBRASKA 68127

1.0 SUBJECT

One- and Two-hour Fire-resistive Gold Bond® Interior Partition Systems.

2.0 DESCRIPTION

2.1 General:

The Gold Bond Interior Partition Systems are designed for use where one- and two-hour, fire-resistive nonload-bearing partitions are required. The partitions may be erected from one side and left unfinished on the service equipment or shaft side; when used to enclose staircases or other occupied areas, they may be finished on both sides. The systems consist of Gold Bond 1-inch-thick (25.4 mm) Fire-Shield® Type X shaftliner board, and either 5/8-inch-thick (15.9 mm) Fire-Shield Type X or 1/2-inch-thick (12.7 mm) Fire-Shield G™ gypsum wallboard, which is supported either by Phillips Manufacturing Company 2 1/2-inch or 4-inch (63.5 mm or 102 mm) No. 25 gage [0.020 inch (0.51 mm)] or No. 20 gage [0.0329 inch (0.83 mm)] galvanized steel I studs, U or J tracks, or by 6-inch (152 mm) No. 20 gage [0.0329 inch (0.83 mm)] galvanized steel I studs, U or J tracks. Phillips Manufacturing Company stud dimensional details are shown in Figure 1. Allowable partition heights are as indicated in Table 1.

2.2 Material:

2.2.1 Gypsum Wallboard: Gold Bond 1-inch-thick (25.4 mm) Fire Shield Type X Shaft Liner board complies with the physical properties requirements in ASTM C 442. Gold Bond Fire-Shield G is a trademark for a proprietary gypsum wallboard that complies with ASTM C 36 for Type X gypsum wallboard. Fire-Shield Type X gypsum wallboard complies with ASTM C 36.

2.2.2 Steel: The steel studs are fabricated from galvanized steel complying with ASTM A 653 SS Grade 40, having a

minimum yield strength of 40,000 psi (275 MPa). The U and J tracks are fabricated from galvanized steel complying with ASTM A 653 CS Grade 33, having a minimum yield strength of 33,000 psi (228 MPa). Studs and tracks are roll-formed from steel having a minimum design bare-steel thickness of 0.020 inch or 0.0329 inch (0.51 mm or 0.83 mm) and a G60 galvanized coating.

2.3 Two-hour-rated Partition—Finished One Side (Shaft-wall):

The construction consists of steel studs and tracks faced on one side with the 1-inch-thick (25.4 mm) Fire-Shield shaftliner panel and on the opposite side with two layers of either 1/2-inch-thick (12.7 mm) Fire-Shield G or 5/8-inch-thick (15.9 mm) Fire-Shield Type X gypsum wallboard. The J track is installed along the ceiling line and vertically to abutting partitions using recognized fasteners spaced a maximum of 24 inches (610 mm) on center. The U-track or J track is installed along the floor line. I studs are installed at 24 inches (610 mm) on center. Shaftliner panels are erected vertically with peripheral shaftliner panel edges secured to the U or J tracks using 1 5/16-inch-long (41 mm) Type S screws spaced 24 inches (610 mm) on center. The other edge, and edges of adjacent shaftliner panels, are secured between the I stud flanges. On the opposite side, two layers of either 1/2-inch-thick (12.7 mm) Fire-Shield G or 5/8-inch-thick (15.9 mm) Fire-Shield Type X gypsum wallboard panels are secured over the studs with the base layer placed horizontally, perpendicular to framing, and fastened to the studs and tracks using 1-inch-long (25.4 mm) Type S buglehead screws spaced 24 inches (610 mm) on center. The face layer is placed vertically, parallel to framing, over the base layer and fastened to the stud framing using 1 5/8-inch-long (41 mm) Type S screws spaced 12 inches (305 mm) on center. As an alternate, the face layer is placed horizontally, perpendicular to framing, over the base layer and fastened to the stud framing using 1 5/8-inch-long (41 mm) Type S screws spaced 12 inches (305 mm) on center in the field and 8 inches (203 mm) on center along the perimeter. For both installations, the joints in the base layer must be staggered with respect to the joints in the face layer. The face layer joints and screw heads are sealed with a joint tape system. The assembly is illustrated in Figure 2.

2.4 Two-hour-rated Partition—Finished Both Sides (Stairwell):

The construction details of the tracks and I studs and the 1-inch (25.4 mm) shaftliner panels are similar to those of the system described in Section 2.3, except that a single layer of 1/2-inch-thick (12.7 mm) Fire-Shield G or 5/8-inch-thick (15.9 mm) Fire-Shield Type X wallboard is applied horizontally, perpendicular to framing, to both the shaftliner side and the

ICC-ES legacy reports are not to be construed as representing aesthetics or any other attributes not specifically addressed, nor are they to be construed as an endorsement of the subject of the report or a recommendation for its use. There is no warranty by ICC Evaluation Service, Inc., express or implied, as to any finding or other matter in this report, or as to any product covered by the report.



open-stud-face side. The wallboard joints on the shaftliner side must be staggered from the wallboard joints on the opposite face. Both face layers are secured to the I studs using 1-inch long (25.4 mm) Type S screws spaced 12 inches (305 mm) on center. All face layer joints are taped. See Figure 3.

### 2.5 Two-hour-rated Partitions with Sound Control:

Construction details are similar to those of the systems described in Sections 2.3 and 2.4, except that the single and  $\frac{5}{8}$ -inch-thick (15.9 mm) Fire-Shield Type X gypsum wallboards are fastened to Phillips Manufacturing Company minimum No. 25 gage [0.0179 inch (0.45 mm)], R.F. resilient channels installed horizontally at 24 inches (610 mm) on center on the opposite side of the shaftliner. The resilient channel is fastened to each stud using  $\frac{3}{8}$ -inch-long (9.5 mm), Type S, pan-head screws alternating along the top and bottom leg. The base layer is attached to the resilient channels using 1-inch-long (25.4 mm), Type S, buglehead screws spaced 24 inches (610 mm) on center along the edges and in the field of the boards, with the first screw 3 inches (76 mm) from the board end. The face layer is attached to the channels using  $1\frac{5}{8}$ -inch-long (41 mm), Type S, buglehead screws spaced 12 inches (305 mm) on center along the edges and in the field of the board, with the first screw 6 inches (512 mm) from the board end.

The cavity is filled with  $1\frac{1}{2}$ -inch-thick (38 mm) Type 75 fiberglass insulation having a minimum 0.75-pcf (12.0 kg/m<sup>3</sup>) density. The top and bottom tracks and both exterior face perimeters are caulked under the tracks.

Partitions constructed as described in this section are recognized as having a minimum STC rating of 50.

### 2.6 One-hour-rated Partition—Finished One Side (Shaftwall):

The construction details are similar to those of the system described in Section 2.3, except that a single layer of  $\frac{5}{8}$ -inch-thick (15.9 mm) Fire-Shield Type X wallboard is applied horizontally, perpendicular to framing, to the open-stud-face side using 1-inch-long (25.4 mm) Type S screws spaced 12 inches (305 mm) on center in the field and along horizontal edges, and 8 inches (203 mm) on center along vertical edges. The wallboard joints and screw heads are sealed with a joint-tape system. See Figure 4.

### 2.7 One- or Two-hour-rated Horizontal Ceilings:

The system provides fire-resistive protection on corridor ceilings and on the underside of stairs in accordance with Section 1004.3.4 of the UBC. The I stud system, as described in Section 2.3 for two-hour construction and in Section 2.6 for one-hour construction, is installed in a horizontal orientation. The I studs are supported by J-tracks that are attached to existing vertical wall framing members using mechanical fasteners spaced a maximum of 24 inches (610 mm) on center. The fasteners must have a minimum allowable load of 200 pounds (889.6 N) in shear or pullout, as applicable, and must be approved by the building official. The I studs are attached to the J-tracks at each end using two  $\frac{1}{2}$ -inch-long (12.7 mm) Type S-12 panhead screws. Maximum horizontal spans are as noted in Table 2.

### 2.8 Two-hour-rated Horizontal Membrane and Duct Protection:

The J-track and I-stud systems are installed in a horizontal orientation as described for two-hour construction in Section 2.7 and as described in Section 2.3, except three layers of  $\frac{1}{2}$ -inch-thick (12.7 mm) Fire-Shield G wallboard are attached to the open-stud-face side as shown in Figure 5. The base and middle layers are applied parallel to the stud framing, with longitudinal joints offset one stud space. The base layer is

secured to the studs using 1-inch-long (25.4 mm) Type S screws spaced 24 inches (610 mm) on center. The middle layer is secured to the studs using  $1\frac{5}{8}$ -inch-long (41 mm) Type S screws spaced 24 inches (610 mm) on center. The face layer is applied perpendicular to the stud framing, with end joints between studs secured, at end joints, to the other layers of wallboard using  $1\frac{1}{2}$ -inch-long (38 mm) Type G screws spaced 8 inches (203 mm) on center and to studs using  $\frac{1}{4}$ -inch-long (57 mm) Type S screws spaced 12 inches (305 mm) on center. Face layer joints and screw heads may be exposed or sealed with a joint-tape system. Maximum horizontal spans are as noted in Table 2.

### 2.9 Alternate Construction:

The Phillips Manufacturing Company  $2\frac{1}{2}$ -, 4- and 6-inch (63.5, 102 and 152 mm) No. 20 gage studs and tracks may be substituted for the No. 25 gage studs and tracks. When using No. 20 gage studs and tracks, Type S-12 fasteners are used in lieu of Type S fasteners.

### 2.10 Identification:

The  $\frac{1}{2}$ -inch-thick (12.7 mm) Fire-Shield G and  $\frac{5}{8}$ -inch-thick (15.9 mm) Fire-Shield Type X gypsum wallboards are identified with the name Gold Bond, and with the name Fire-Shield G or Fire-Shield Type X, respectively, on the front of each piece or on the bundling tape. The 1-inch-thick (25.4 mm) shaftliner panel is identified with the names Gold Bond and Fire-Shield Shaftliner on the front of each piece or on the bundling tape.

Each I-stud member has a label identifying the evaluation report number (ICBO ES ER-3579). Additionally, each stud, U and J track is embossed every 48 inches (1219 mm) with the Phillips Manufacturing Company name, the evaluation report number (ICBO ES ER-3579), the base-metal thickness, and the yield strength (F40).

## 3.0 EVIDENCE SUBMITTED

Reports of fire endurance tests in accordance with UBC Standard 7-1, sound transmission tests in accordance with ASTM E 90 and ASTM E 413, and reports of tests in accordance with the ICBO ES Acceptance Criteria for Determining Limiting Heights of Composite Walls Constructed of Gypsum Board and Steel Studs (AC86), dated July 1995.

## 4.0 FINDINGS

**That the National Gypsum Company Gold Bond interior partition systems described in this report comply with the 1997 Uniform Building Code™, subject to the following conditions:**

- 4.1 The materials and method of installation comply with this report and the manufacturer's instructions.
- 4.2 The maximum unsupported partition heights are as set forth in Table 1, and maximum unsupported horizontal spans are as set forth in Table 2.
- 4.3 All cut openings and horizontal joints in the shaftliner used with the finished one-side systems must be encased within the metal framing system. As an alternative, minimum 6-inch-wide (152 mm) strips of  $\frac{1}{2}$ -inch-thick (12.7 mm) Fire-Shield G gypsum wallboard, attached using two  $1\frac{1}{2}$ -inch-long (38 mm) Type G screws on each side of the joint, may be used.
- 4.4 Studs are manufactured by Phillips Manufacturing Company at 504 Walnut Street, in Niles, Ohio.

**This report is subject to re-examination in two years.**

TABLE 1—ALLOWABLE WALL HEIGHTS FOR NATIONAL GYPSUM COMPANY I-STUD ASSEMBLIES

WALL SYSTEM	ALLOWABLE DEFLECTION	DESIGN LOAD			
		5 psf	7.5 psf	10 psf	15 psf
1-hour 2½-inch 25 Gage Shaftwall	L/120 L/240 L/360	13' - 4" 10' - 7" 9' - 3"	11' - 7" 9' - 3" 8' - 11"	10' - 1" 8' - 5" 7' - 4"	8' - 3" 7' - 4" 6' - 5"
1-hour 2½-inch 20 Gage Shaftwall	L/120 L/240 L/360	15' - 2" 12' - 1" 10' - 7"	13' - 3" 10' - 7" 9' - 2"	12' - 1" 9' - 7" 8' - 4"	10' - 7" 8' - 4" 7' - 4"
1-hour 4-inch 25 Gage Shaftwall	L/120 L/240 L/360	17' - 11" 14' - 3" 12' - 5"	14' - 10" 12' - 5" 10' - 10"	12' - 10" 11' - 4" 9' - 5"	9' - 9" 9' - 5" 8' - 3"
1-hour 4-inch 20 Gage Shaftwall	L/120 L/240 L/360	20' - 0" 16' - 6" 14' - 5"	18' - 2" 14' - 5" 12' - 7"	16' - 6" 13' - 1" 11' - 5"	14' - 3" 11' - 5" 9' - 4"
1-hour 6-inch 20 Gage Shaftwall	L/120 L/240 L/360	24' - 0" 20' - 11" 18' - 4"	22' - 10" 18' - 4" 16' - 0"	19' - 9" 16' - 8" 14' - 6"	16' - 2" 14' - 6" 10' - 11"
2-hour 2½-inch 25 Gage Shaftwall	L/120 L/240 L/360	14' - 7" 11' - 7" 10' - 1"	12' - 4" 10' - 1" 8' - 10"	10' - 9" 9' - 2" 8' - 0"	8' - 9" 8' - 0" 7' - 0"
2-hour 4-inch 25 Gage Shaftwall	L/120 L/240 L/360	17' - 9" 14' - 1" 12' - 4"	15' - 6" 12' - 4" 9' - 8"	14' - 1" 11' - 2" 8' - 9"	12' - 4" 8' - 9" 7' - 8"
2-hour 4-inch 25 Gage Shaftwall	L/120 L/240 L/360	19' - 10" 16' - 2" 14' - 2"	16' - 3" 14' - 2" 11' - 0"	14' - 0" 11' - 6" 10' - 0"	10' - 2" 10' - 0" 8' - 9"
2-hour 4-inch 20 Gage Shaftwall	L/120 L/240 L/360	23' - 2" 18' - 4" 16' - 1"	20' - 2" 16' - 1" 14' - 0"	18' - 1" 14' - 7" 11' - 1"	14' - 9" 11' - 1" 9' - 8"
2-hour 6-inch 20 Gage Shaftwall	L/120 L/240 L/360	28' - 0" 22' - 9" 19' - 10"	23' - 11" 19' - 10" 17' - 4"	20' - 9" 18' - 0" 12' - 10"	16' - 11" 12' - 10" 11' - 2"
2-hour 2½-inch 25 Gage Stairwell	L/120 L/240 L/360	13' - 11" 11' - 0" 9' - 8"	12' - 2" 9' - 8" 8' - 5"	11' - 0" 8' - 9" 7' - 8"	9' - 8" 7' - 8" 6' - 8"
2-hour 2½-inch 20 Gage Stairwell	L/120 L/240 L/360	16' - 7" 13' - 2" 11' - 6"	14' - 6" 11' - 6" 10' - 0"	13' - 2" 9' - 10" 8' - 7"	11' - 6" 8' - 7" 7' - 6"
2-hour 4-inch 25 Gage Stairwell	L/120 L/240 L/360	20' - 2" 16' - 0" 11' - 11"	17' - 8" 11' - 11" 10' - 5"	16' - 0" 10' - 10" 9' - 5"	11' - 11" 9' - 5" 8' - 3"
2-hour 4-inch 20 Gage Stairwell	L/120 L/240 L/360	22' - 3" 17' - 8" 15' - 6"	19' - 6" 15' - 6" 11' - 9"	17' - 8" 14" - 1" 10' - 8"	15' - 6" 10' - 8" 9' - 4"
2-hour 6-inch 20 Gage Stairwell	L/120 L/240 L/360	28' - 0" 22' - 7" 19' - 9"	24' - 10" 19' - 9" 13' - 6"	22' - 7" 17' - 11" 12' - 3"	19' - 9" 12' - 3" 10' - 9"

For SI: 1 inch = 25.4 mm, 1 foot = 305 mm, 1 psf = 47.9 Pa.

<sup>1</sup>Allowable heights are based on transverse load tests complying with AC86, with studs spaced a maximum of 24 inches on center.

<sup>2</sup>Limiting heights in this table are the lesser of the heights based on deflection and on strength.

TABLE 2—MAXIMUM HORIZONTAL SPANS<sup>1,2</sup>

SYSTEM I-STUD SIZE AND THICKNESS [inches (gage)]	CORRIDOR CEILINGS AND UNDERSIDE OF STAIRS			HORIZONTAL MEMBRANE AND DUCT PROTECTION Two-hour rating
	One-hour Rating	Two-hour Rating		
		With 1/2-inch boards	With 5/8-inch boards	
2 1/2 (25)	7' - 8"	7' - 8"	7' - 7"	7' - 2"
2 1/2 (20)	8' - 8"	9' - 4"	9' - 2"	8' - 8"
4 (25)	10' - 3"	10' - 9"	10' - 7"	10' - 0"
4 (20)	11' - 9"	12' - 11"	11' - 11"	11' - 3"
6 (20)	14' - 10"	14' - 10"	14' - 8"	13' - 10"

For SI: 1 inch = 25.4 mm, 1 foot = 305 mm.

<sup>1</sup>Calculations based on systems supporting twice their own dead weights, and should not be used where there is access to an attic or loft space above, or anywhere where there is any probability of storage above.

<sup>2</sup>Spans are based on a deflection limitation of L/240.

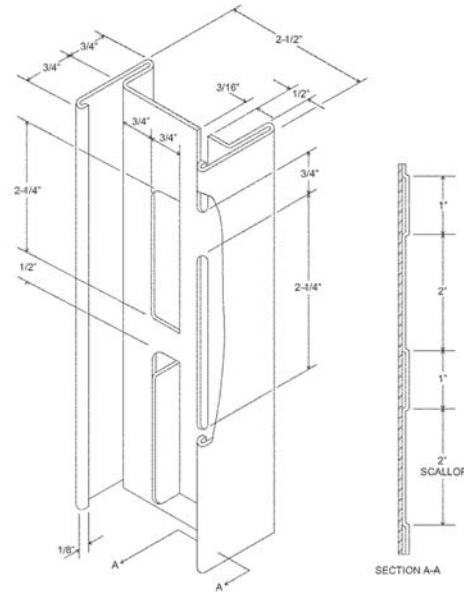

FIGURE 1

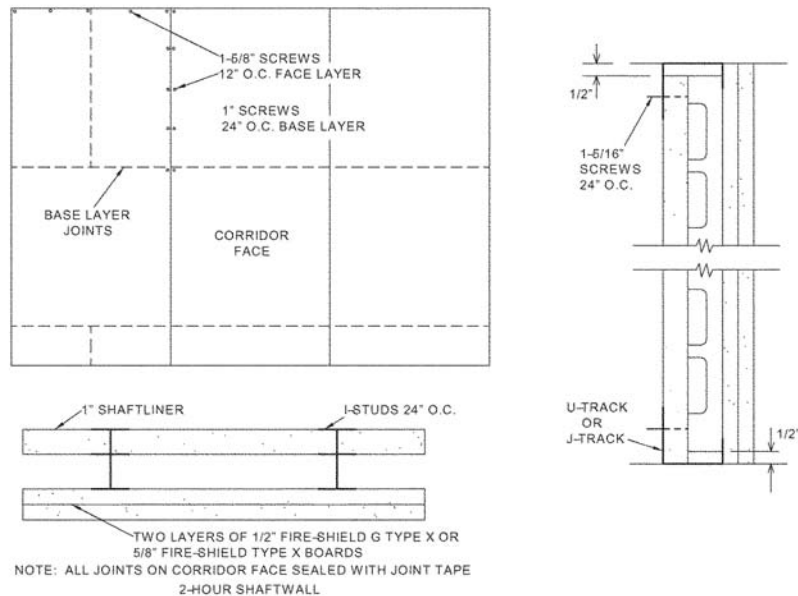

FIGURE 2

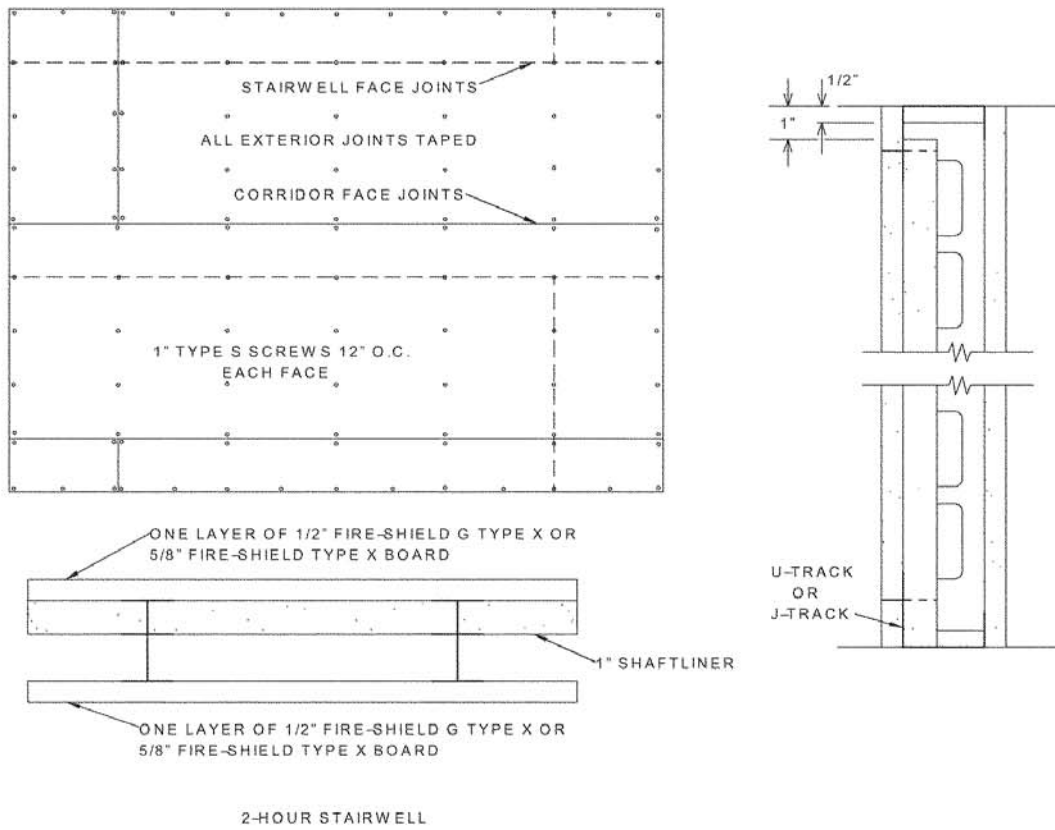

FIGURE 3

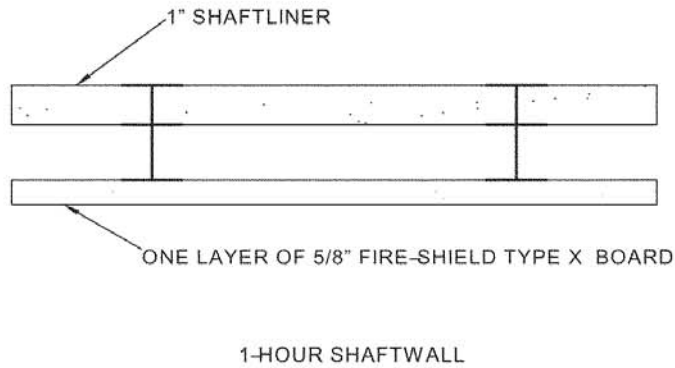

FIGURE 4

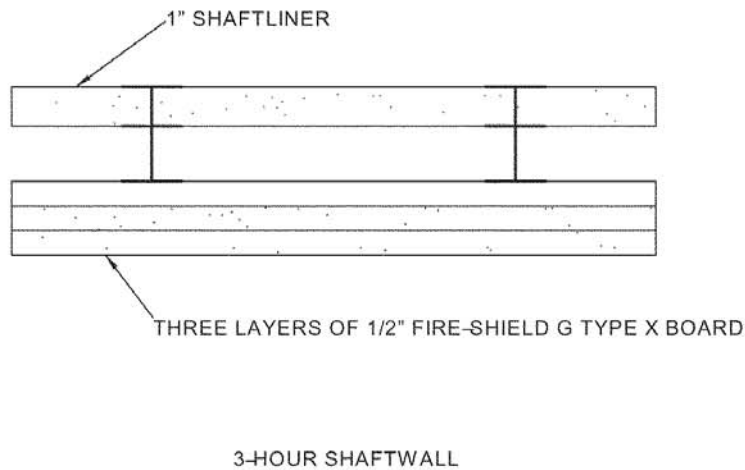

FIGURE 5